



INSTALLATION AND MAINTENANCE MANUAL

FELICIA 45MA TURBINE STARTER

YufanMachineryTechnology(Shanghai)Co.,Ltd.

Address:2 Floor,BuildingF, 123XinjinRoad,Qingpu District,Shanghai
PostalCode:201700 Mobile:+86-18817887163 Tel:021-59283219
Fax: 021-69767217 E-mail:mike@yfstart.com

NOTICE

THIS MANUAL CONTAINS IMPORTANT SAFETY INFORMATION. IT IS IMPORTANT THAT THE ENTIRE CONTENTS BE STUDIED BEFORE INSTALLATION AND OPERATION. IT ONLY REFLECTS GENERIC INFORMATION RELATING TO A STANDARD FELICIA 45MA TURBINE STARTER. VARIOUS OTHER OPTIONS ARE AVAILABLE TO PROVIDE INERTIA DRIVE SYSTEMS, HARSH ENVIRONMENT MUFFLERS OR THEADED EXHAUSTS TO MEET SPECIFIC APPLICATION REQUIREMENTS.

FOREWORD

This manual contains instructions for the installation, maintenance and operation of your new FELICIA 45MA Air Starter Motor. It has been designed to provide you with safe and reliable service. However, it is both a pressure vessel and a piece of rotating machinery.

Therefore operators and maintenance personnel must exercise good judgement and appropriate safety practices to avoid damage to the equipment and prevent personal injury. The instructions in this manual are intended for personnel with a general training in the operation and maintenance of air starter equipment. It should be understood that the information contained in this manual does not relieve the operating and maintenance personnel of the responsibility for exercising good normal judgement in the operation and care of air starter equipment and their associated systems.

Throughout this manual you will encounter the words: 'WARNING', 'CAUTION' and 'NOTICE'. These paragraphs are intended to emphasise certain areas where personnel safety and satisfactory starter operation may be compromised should the message be ignored. The definitions of these words are as follows:-



An operating procedure, practice, etc. that if not strictly observed could result in personal injury.

CAUTION

An operating procedure, condition, etc. that if not followed, could result in damage to, or the destruction of equipment.

NOTICE

An operating procedure, condition, etc. that is essential to highlight and observe.

It is advisable that a safety program be established to address the safety issues detailed within this manual before installing, operating or maintaining this equipment. It is important such a program cover the hazards associated with compressed air.



Do not install this starter other than in accordance with the instructions detailed in this manual.

These instructions should be read completely before beginning installation and should be available to personnel responsible for operating and maintaining this equipment. The unit is capable of trouble free operation when properly applied, installed and maintained.

Extra copies of this manual are available from your local FELICIA Air Starter distributor or the factory.

This manual is designed to cover all situations normally experienced when installing, operating and maintaining this equipment. In the event situations are encountered that are not covered by this manual, consult your FELICIA Agent or Yufan Machinery Technology (Shanghai) Co., Ltd direct.

INSTALLATION AND PREPARATION FOR OPERATION



- Maximum pressure for FELICIA starting equipment is 150psi (10.3Bar), standard operating pressure is 100psi (6.9Bar).
- Ensure air supply is isolated before installation, removal, maintenance or adjustment of your FELICIA starter.
- Before any starter is taken out of service first bleed the air receiver of air and any moisture that may have accumulated by opening up the drain valve. Do not bleed by removing the receiver plugs.
- Remove air hoses to ensure complete safety once the air supply has been isolated and the receiver has been bled.
- The air receiver must be manufactured to an applicable pressure vessel code such as AS1210 or similar.
- Only use air hoses and fittings that are of adequate size as indicated in the installation schematic (page 7).
- Always carry out a pressure test on the complete starting system according to Page 4 before beginning operation. Do not begin operations until satisfied the unit has been installed correctly.
- Do not initiate a start until all components have stopped rotating, this includes the engine and starter motor.
- Always use recommended lubricants where prescribed by this manual. Under no circumstances use flammable or volatile liquids.
- Ensure all fasteners are torqued to the values prescribed in this manual. Use thread sealant where indicated.
- To ensure warranty provisions are not invalidated use only genuine FELICIA replacement parts. Non-genuine parts may cause service and performance problems and may affect the safe operation of your starter.

PRELIMINARY INSTALLATION REQUIREMENTS

1. Your FELICIA starter is flange mounted. Before installing the starter carefully study the mating position of the FELICIA starter and engine flanges to determine whether the air inlet port orientation or nose housing geometry will suit your particular installation. If not suitable re-orientate as follows -
 - Carefully remove the band clamp, but do not remove. The two housings can now be rotated relating to each other without separation.
 - Re-orientate the housings to the desired position and torque the band clamp to 4ft lb (6Nm).
2. Ensure pinion is suitable for engine application i.e. correct pitch, diameter and number of teeth.
3. Check flange to ring gear (FRG) spacing is correct and that flange spacers are not required. Pinions should be FRG less 6mm when at rest.
4. Check FELICIA starter clears all obstacles and the flange mounts to flywheel housing squarely without using undue force.
5. Ensure the hoses, fittings and starter ports are clean and free from dirt and foreign objects. Ensure they remain so during installation.
6. For optimum FELICIA starter performance, ensure air supply pipes or hoses have an internal diameter of at least 25mm (refer Installation Schematic on page 7). In the event line, length must be longer than 5m (a size of 40mm) should be used. Keep the number of fittings and the length of piping to a minimum. Avoid the use of reducing bushes and other fittings that could impede airflow.

INSTALLING THE STARTER AND PIPEWORK

1. The air supply line should ideally exit from the top or side of the air receiver.

CAUTION

Do not connect air supply line to the bottom of the air receiver. Moisture and system contaminants collect at the receiver bottom and can damage the FELICIA starter internals if allowed to pass through. Periodically drain moisture from the air receiver using a drain valve connected at the receiver bottom.

2. Install a 100 mesh 'Y' strainer. A 'Y' strainer installed before the relay valve will provide protection to the valve and FELICIA starter from contaminants that may have accumulated in the air receiver. Fitting of an inline 'Y' strainer (as described above) is also required to ensure the FELICIA starter is covered by our product warranty.

NOTICE

Ensure the inlet side of the 'Y' strainer faces the receiver ie. the direction arrow points away from the receiver.

Connect the inlet of the control valve to the outlet of the 'Y' filter.

NOTICE

Ensure the inlet side of the relay valve connects to the exit side of the 'Y' strainer.

3. Mount the starter control button SC25 onto the vehicle dash-board or appropriate control panel and connect to the air receiver using a minimum of 1/4" (6mm) line.

NOTICE

Ensure the inlet side of the starter control button connects to the line from the receiver. Any safety 'switches' should be installed in this line between the starter control button and the air receiver.

4. After installing the starter motor, the main air supply pipe from the control valve to the motor air inlet can be selected as 1-1/4 caliber according to the actual situation. Alternatively, you can connect the air pipe to the motor first, and then install the motor..
5. Once the FELICIA starter is mounted, fit the remaining 1/4" (6mm) control lines from the FELICIA starter to the starter control button and relay valve respectively (refer page 7).
6. Make all hose or pipe connections leak proof using a suitable thread sealant.
7. Once the connections have been made, pressurise the system and check for leaks using 'soapy' water or similar solution

Main characteristics@100PSI (6.9Bar)

Item	45MA SERIES
Displacement:	15-160 L
Speed Range:	0-4100 RPM
Power:	40.4 KW
Max. Torque:	371.2 N·m
Gas consumption:	517 L/s
Max. Working Pressure:	10.3Bar
Temperature:	-30 °C to +80°C
Rotation:	CW或CCW (Face to pinion)
Housing Material:	Iron
Weight:	≈17.2KG
Optional:	Custom flange、Beryllium copper pinion

Starter Outline Drawing

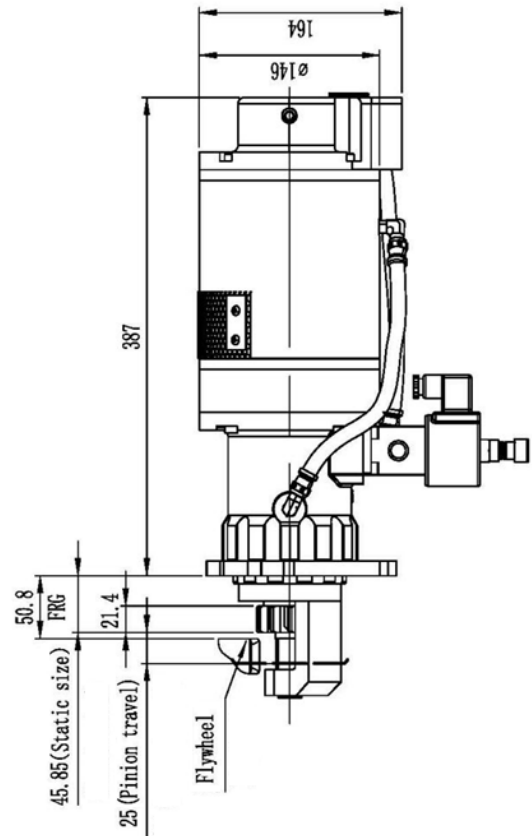
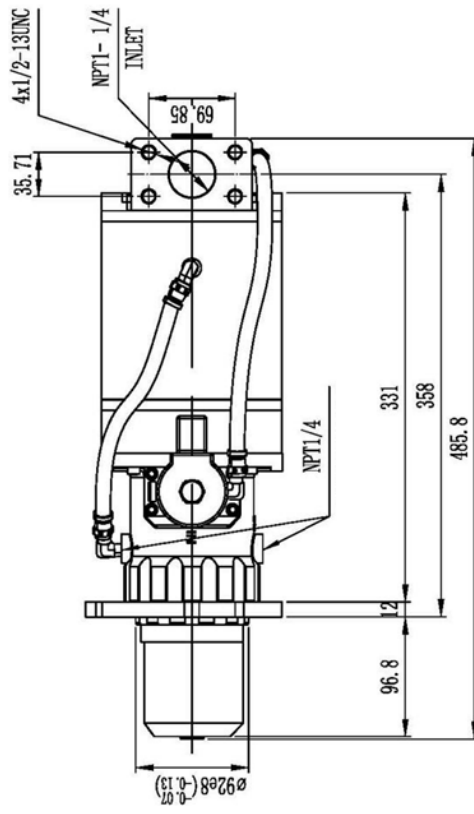
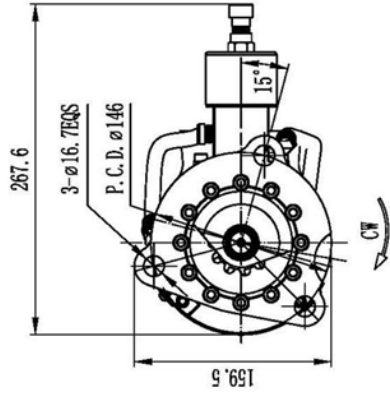

Starting System Diagram

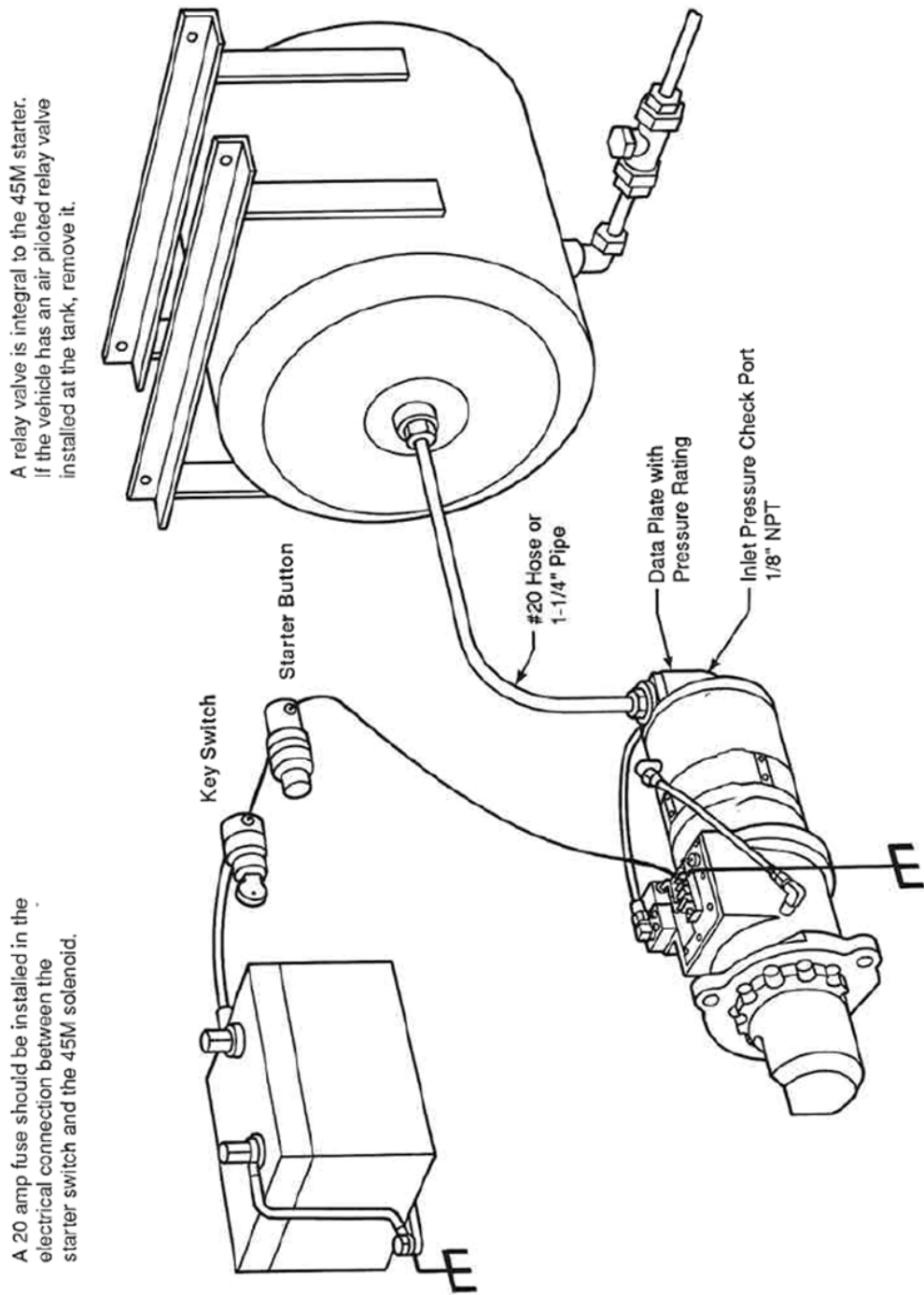

Please refer to the following operations for motor installation angle adjustment and replacement of drive components:

- STEP 1: Remove the hexagon socket screws connecting the nose housing to the connection block, then take off the nose housing..
- STEP 2: Replace damaged drive components .
- STEP 3: Fit the nose housing and rotate it to the appropriate angle.
- STEP 4: Tighten the hexagon socket screw (screw tightening torque: 24 N•m).

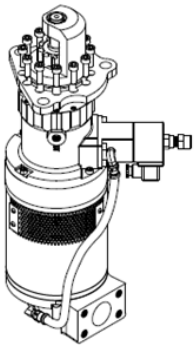

STEP1

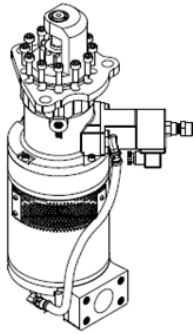

STEP2

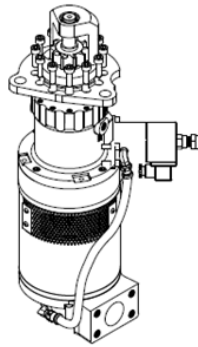

STEP3

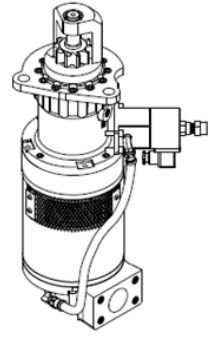

STEP4

If there are any issues during the repair and installation process, please contact the dealer or directly contact Yufan Machinery Technology (Shanghai) Co., Ltd.

WARRANTY POLICY

All FELICIA Products supplied by Yufan Machinery Technology (Shanghai) Co., Ltd. (herein called "the Manufacturer") is warranted to be free from any defect in workmanship and material under conditions of normal use and service for engine starting applications for a period of 12 months from the date of purchase by the first user. Normal wear and tear is excluded from the warranty cover.

The Manufacturer will replace or repair at their works, without cost, any FELICIA Starter or parts found to be defective or at their discretion choose to refund the purchase price less a reasonable allowance for depreciation in exchange for the starter or part should the item prove impossible to repair or replace.

This warranty shall not apply to any FELICIA Starter or parts which have been altered or repaired or purchased outside the Manufacturer and its assigned agents nor to equipment or parts that have been subject to misuse including overloading, neglect, accident or damage, nor to any part or parts improperly applied or installed.

This warranty is in lieu of all other warranties and conditions statutory or otherwise expressed or implied and of all other obligations or liabilities on the Manufacturer's part. The Manufacturer's maximum liability is limited to the purchase price of the starter and is not liable for any consequential damage, loss or expense.

Repeat engine starting attempts must be delayed for 15 seconds to allow all FELICIA Starter and engine components to stop rotating to avoid damage or adverse wear of components.

